

# STEP for linoleum.idw

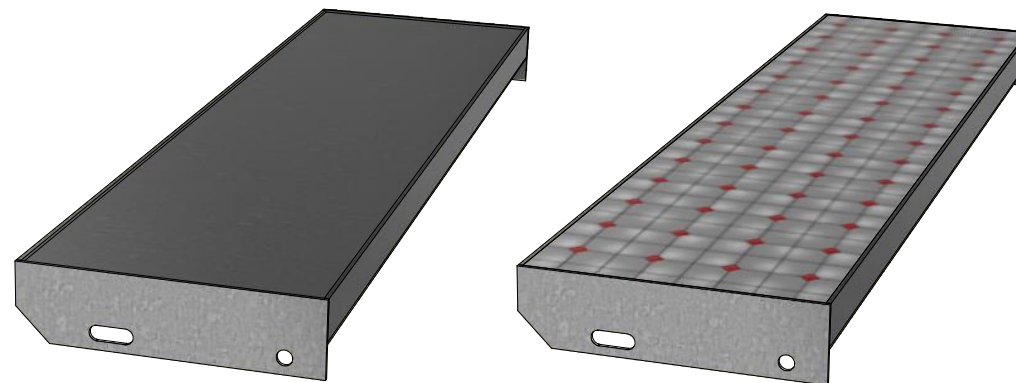
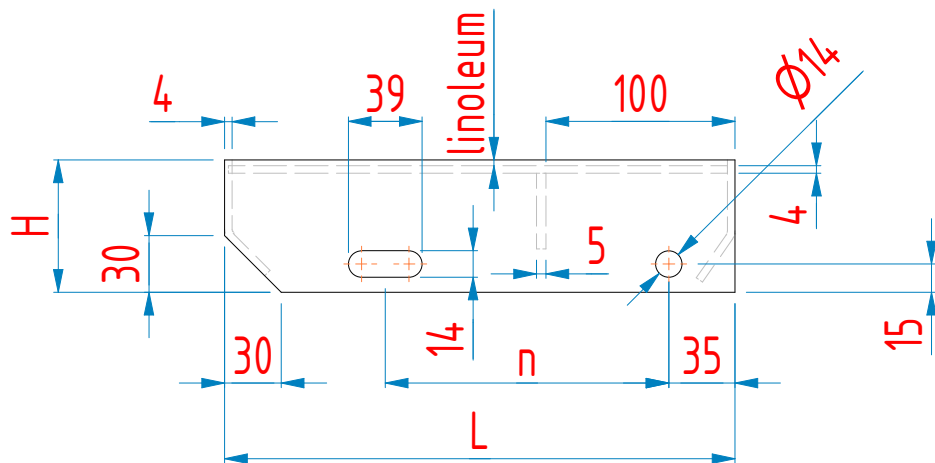

TABLE OF END PLATES t=4mm

L [mm]	n [mm]
200	80
240	120
270	150
305	180



Comments  
 1. All indeterminate welds: T-welds as fillet welds a = 3  
 2. Connection of elements do as butt welds with full penetration  
 3. With hot-dip galvanized components, welds should be closed.

General tolerances regarding the construction welded according to NS/SS-EN ISO 13920 class B

PN-EN 1090 EXC2, CE	General tolerances regarding the construction welded according to NS/SS-EN ISO 13920 class B					
	Above 30 to 120	Above 120 to 400	Above 400 to 1000	Above 1000 to 2000	Above 2000 to 4000	Above 4000
	±1	±2	±3	±4	±6	±8

Material  
 Steel S235JR  
 NS/SS-EN 10025-2

Antal Quantity	Vi ansvarar ej för trappans stabilitet vid infästningspunkter mot omkringliggande konstruktion.			
	Titel Title	Ytbehandling surface treatment		
Massa Mass		Gen. tolerans General Tolerances	Skala Scale	
Konstr. Godk.		EN ISO13920:1996 cl.B	Ref.dwgs	
		Ritn.nr DwgNo		Rev