

# ABC STANDARD GATE FOR STRAIGHT STAIRS.idw

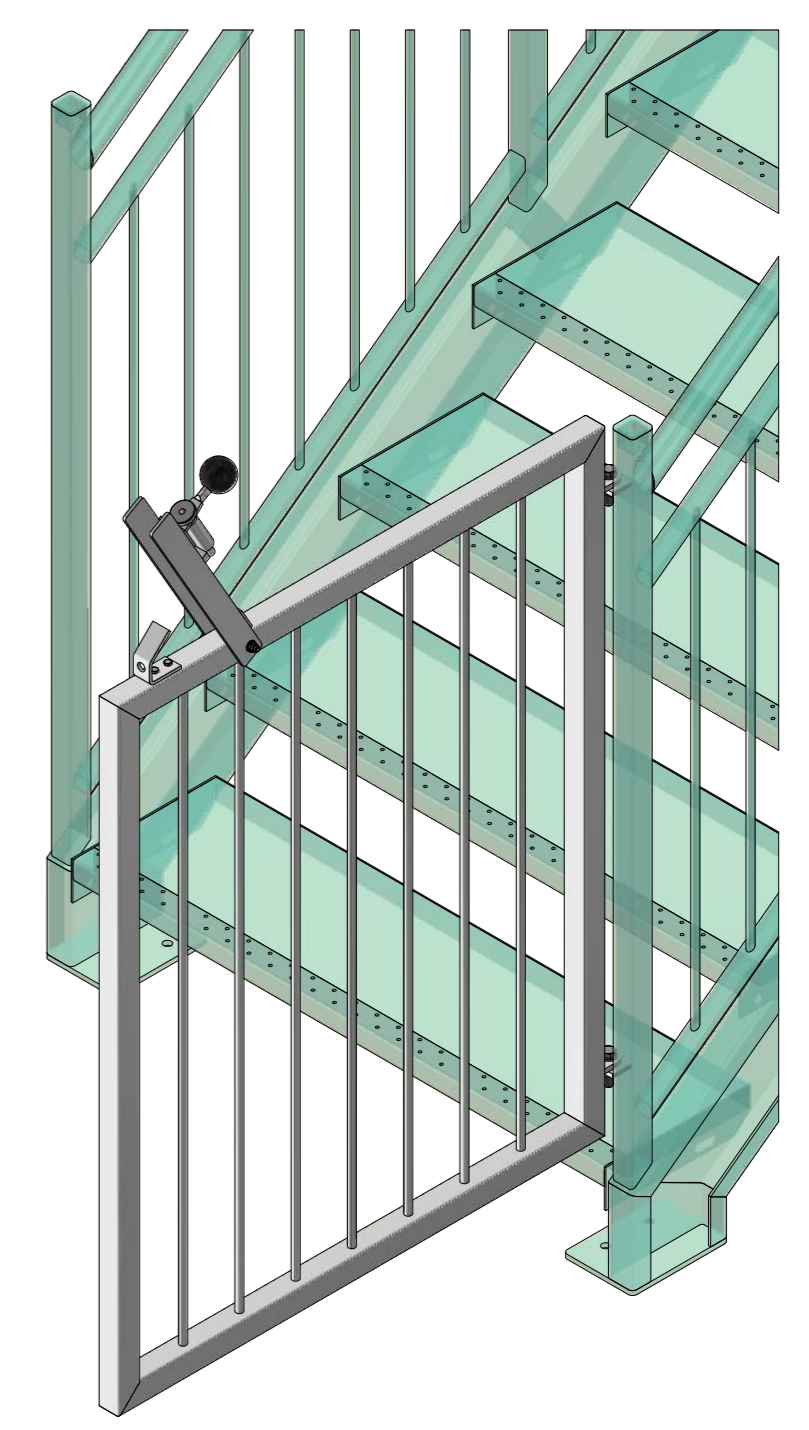

Details: see folder  
"Lock system / Hinges"

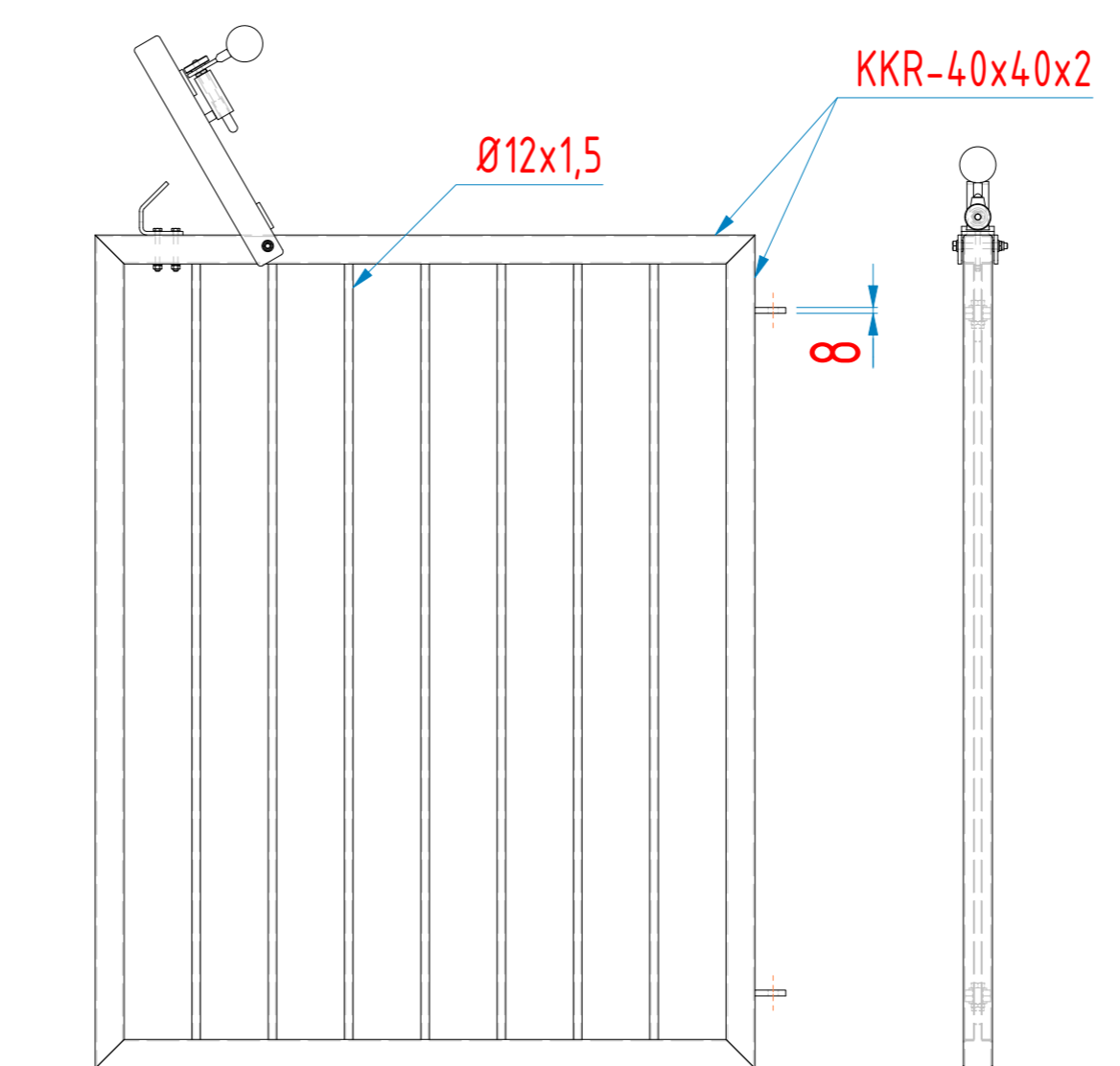
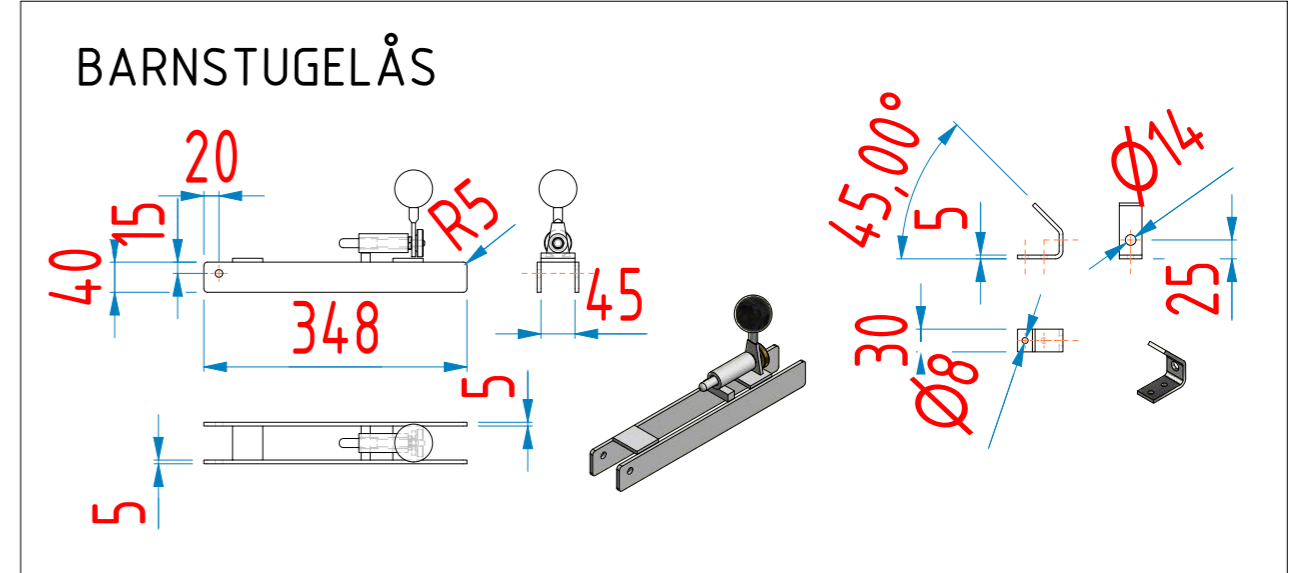
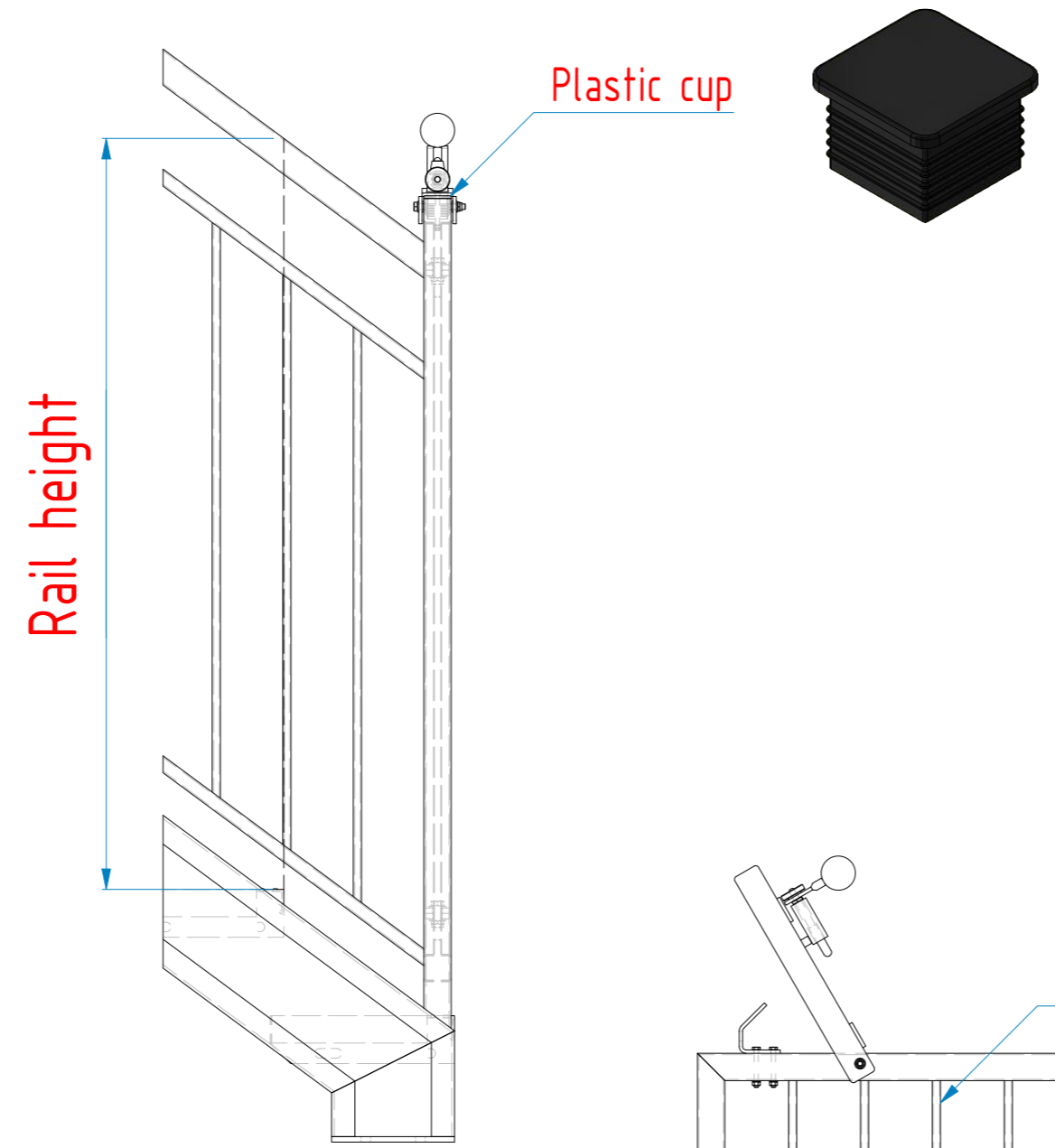
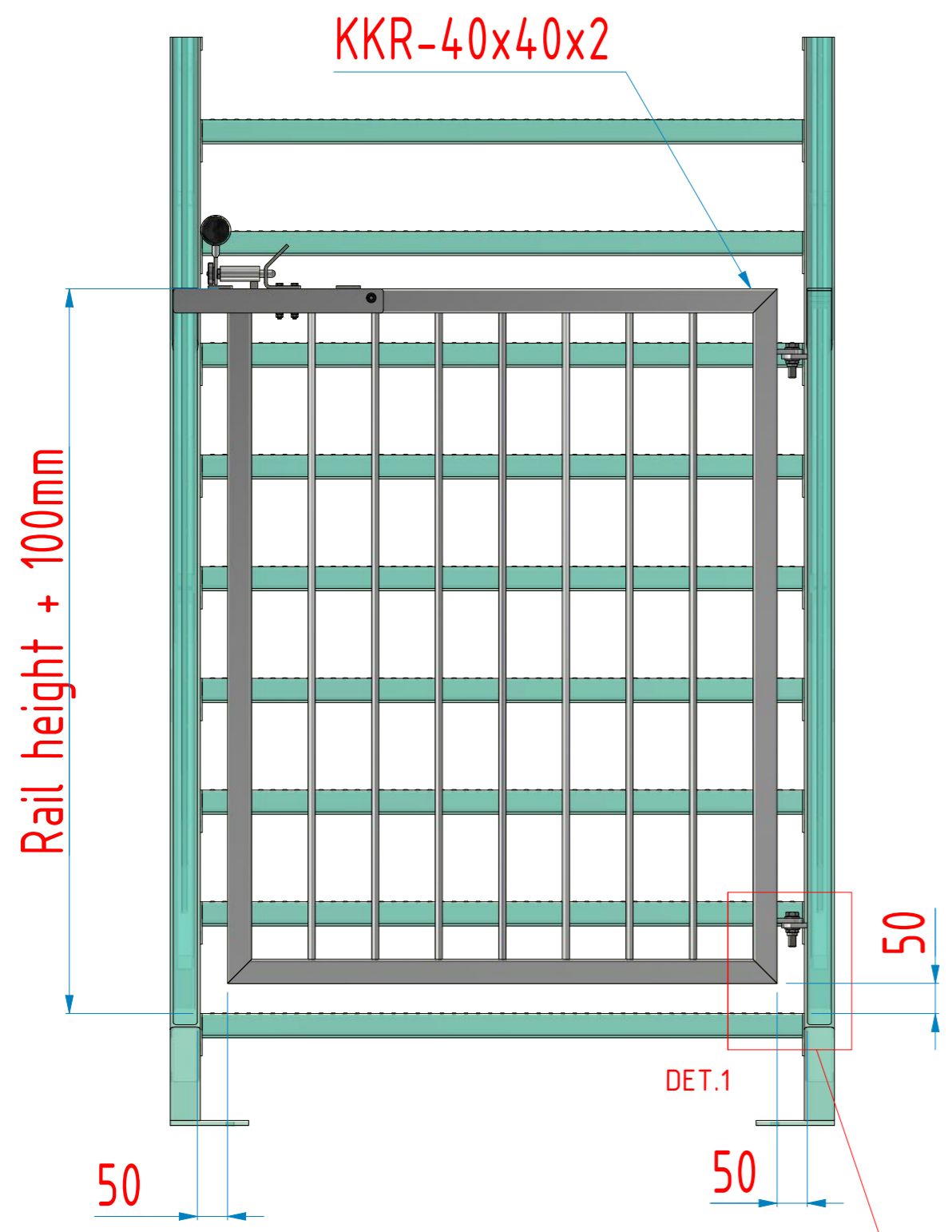
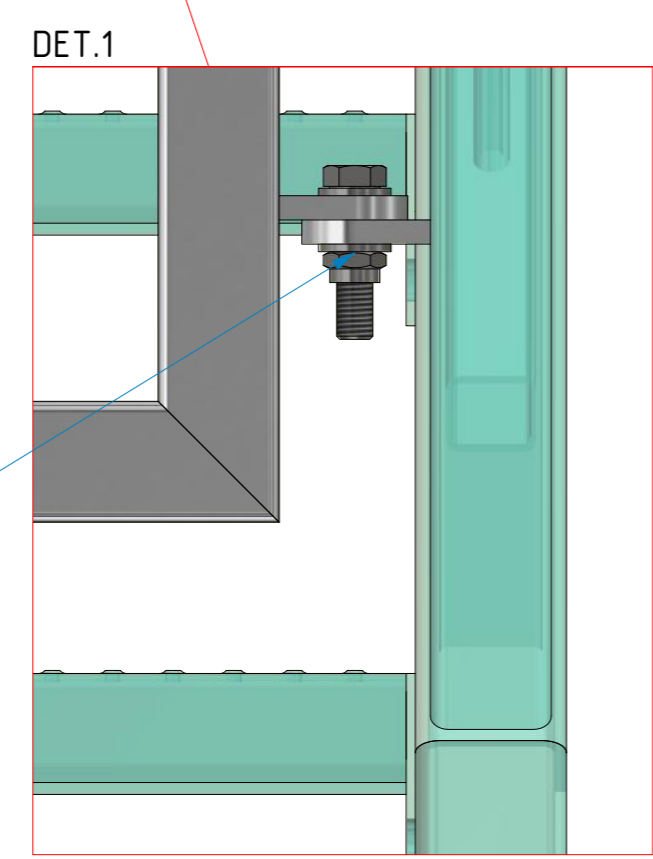

Fixing Elements	Standard	Reference	Quality
M8 x 70 Hexagonal head bolt	DIN 931 / ISO 4014	Barnstugelås	A4
M8 Self-locking hexagon nut	DIN 985 / ISO 10511	Barnstugelås	A4
Washer for M8	DIN 125 / ISO 7089	Barnstugelås	A4
M6 x 55 Hexagonal head bolt	DIN 931 / ISO 4014	Barnstugelås x2	A4
M6 Hexagon nuts	DIN 934 / ISO 4033	Barnstugelås x2	A4
Washer for M6	DIN 125 / ISO 7089	Barnstugelås x2	A4
M12 x 50 Hexagonal head bolt	DIN 931 / ISO 4014	Hinge	A4
M12 Self-locking hexagon nut	DIN 985 / ISO 10511	Hinge	A4
Washer for M12	DIN 125 / ISO 7089	Hinge	A4

Comments	P/N: EN 10204 ECCZ; CE	General tolerances regarding the construction welded according to NS/SS-EN ISO 13920 class B						Material Steel S235JR NS/SS-EN 10025-2
		Above 30 to 120	Above 120 to 400	Above 400 to 1000	Above 1000 to 2000	Above 2000 to 4000	Above 4000	
1. All indeterminate welds: T-welds as fillet welds a = 3 2. Connection of elements do as butt welds with full penetration 3. With hot-dip galvanized components, welds should be closed.		s1	s2	s3	s4	s6	s8	

Vi ansvarar ej för trappans stabilitet vid infästningspunkter mot omkringliggande konstruktion.

Titel: ABC STANDARD GATE FOR STRAIGHT STAIRS.idw

Skala: 1:20

Material: Steel S235JR

Rev: 01

ABC SOLUTIONS

Master: Skuggen Väg 7  
44176 ÅBRÖKA, SWEDEN  
Tel: 0519-181017  
www.abcstair.com